

## INTRODUCING EPPUR DREEFT



*Designed, machined and assembled in France*



*PS: Thank's Mathéo B for the *

*FOLLOW US FOR THE LATEST NEWS!*



[eppur@muvetech.com.au](mailto:eppur@muvetech.com.au)  
[www.muvetech.com.au](http://www.muvetech.com.au)  
[www.eppur.eu](http://www.eppur.eu)



# \_DREEFT

*Do you want to brake free?*



# E P P U R



# SLOW DOWN

**The first braking device for manual wheelchairs**  
*A set of wheels to slow down with no pain*



Today, braking or turning a wheelchair implies using your hands as brake pads, causing shoulder pain and hand burns.

Thanks to Dreeft wheels, brake with your fingertips with no effort or friction!

Just lightly pull the handrim backwards to activate the coaster brake system.



# GO FURTHER

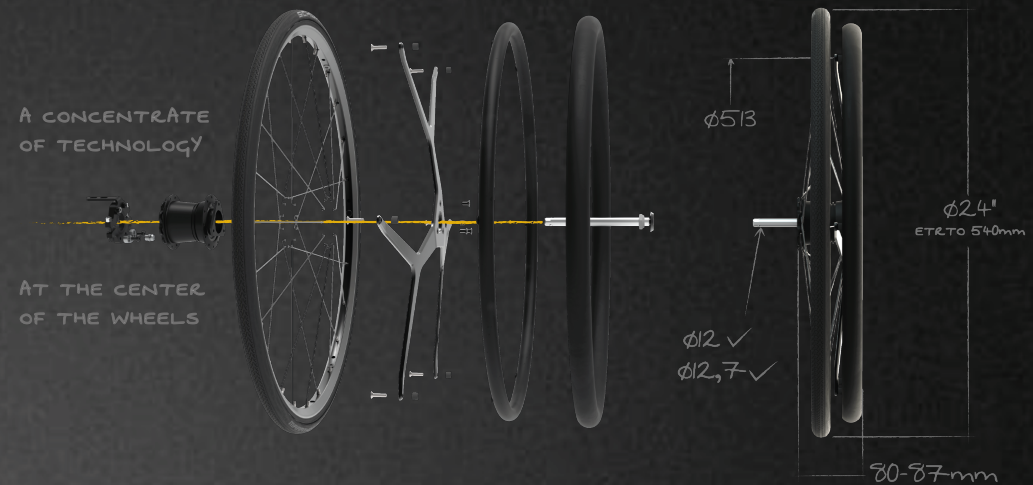

## TECHNICAL DATASHEET

Wheel dimensions :	24" (ETRTO 540mm)	Spokes :	24 spokes 14G black steel
Tyres :	Schwalbe Marathon+ 25-540	Handrim fixation part :	Black powder coated aluminium
Handrims :	Black anodized aluminium $\phi 19$ mm	Quick release axis diameter :	Compatible with 12mm & 12,7mm
Rims :	Double wall, aluminium	Handrim-to-rim spacing :	12 mm or 19mm
Handrim grip :	PVC rubber hand grip $\phi 30$ mm	Max user weight :	100 kg
		Fully equipped wheel weight :	3 750 g



### Zero friction

Say goodbye to gloves and hand burns



### 80% Less effort

Compared to standard wheels  
(Your shoulders will say thank you)



### Motorizable

Helps you steer with rear power assist  
No pain, no danger!



### Appropriate for para&quadri

Usable without hand gripping,  
even under the rain!