

alber

**Damit Schieben
einfach wird**

viamobil[®]eco

Brems- und Schiebehilfe

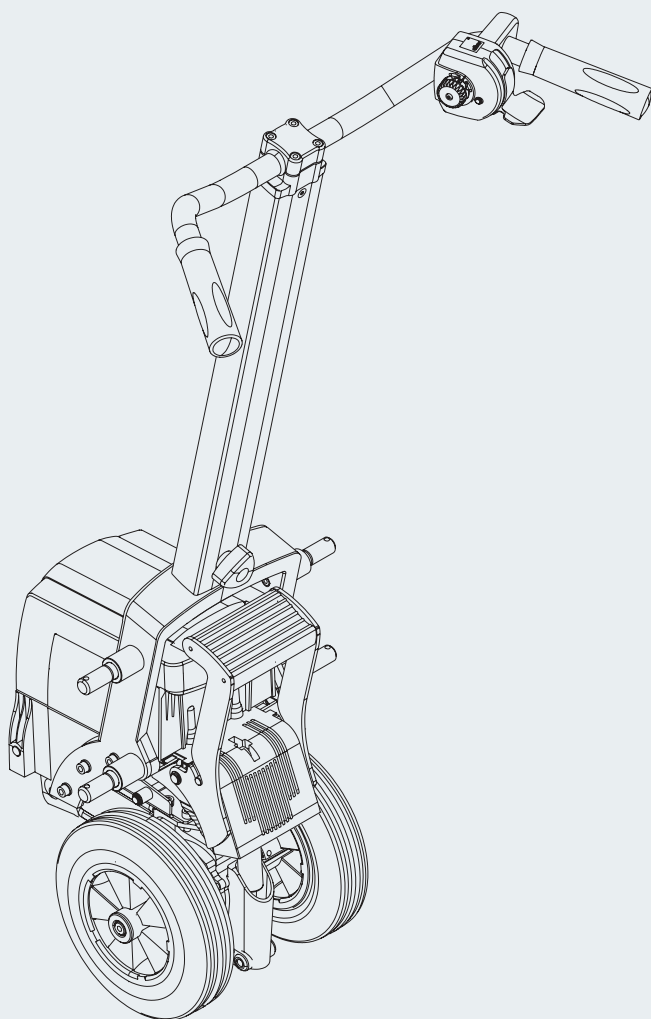

Gebrauchsanweisung

D

User manual

GB/US

Instructions d'utilisation

F

Brugsvejledning

DK

Gebruiksaanwijzing

NL

CE

Service Center (Deutschland)

Montag bis Donnerstag von

8.00 - 18.00 Uhr

Freitags von

8.00 - 16.00 Uhr

erreichbar unter

Telefon (0800) 9096-250

(gebührenfrei)



Das viamobil ist klassifiziert
als Gerät Typ B.



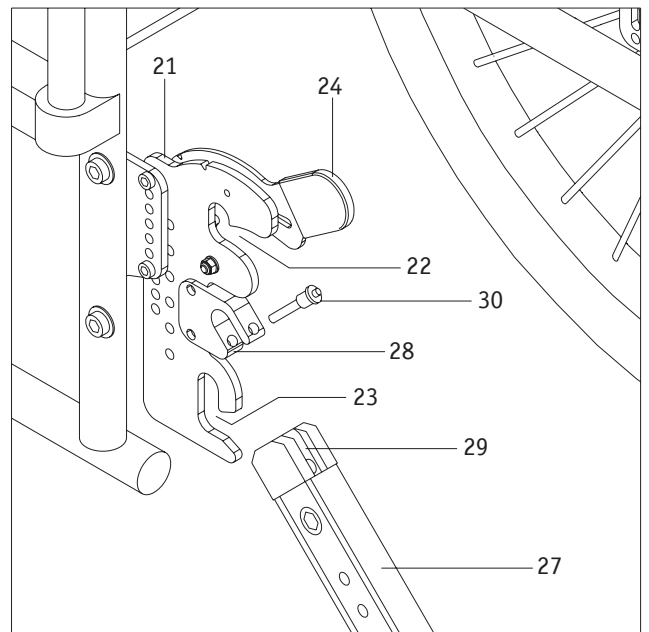
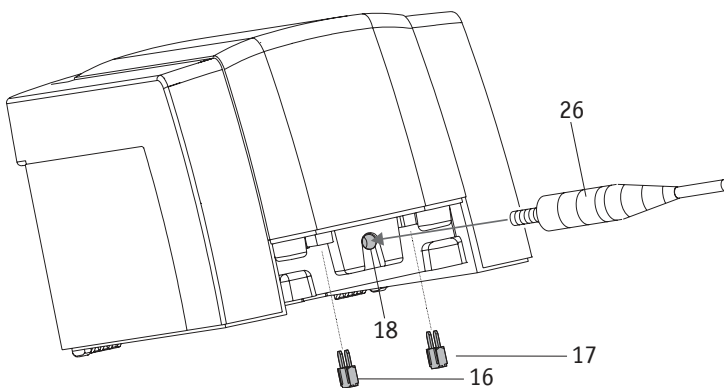
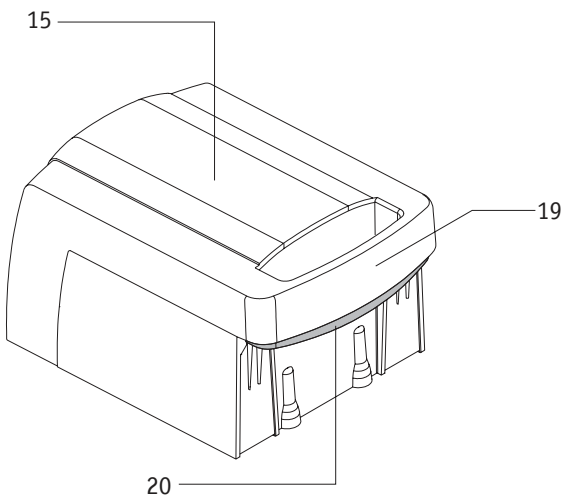
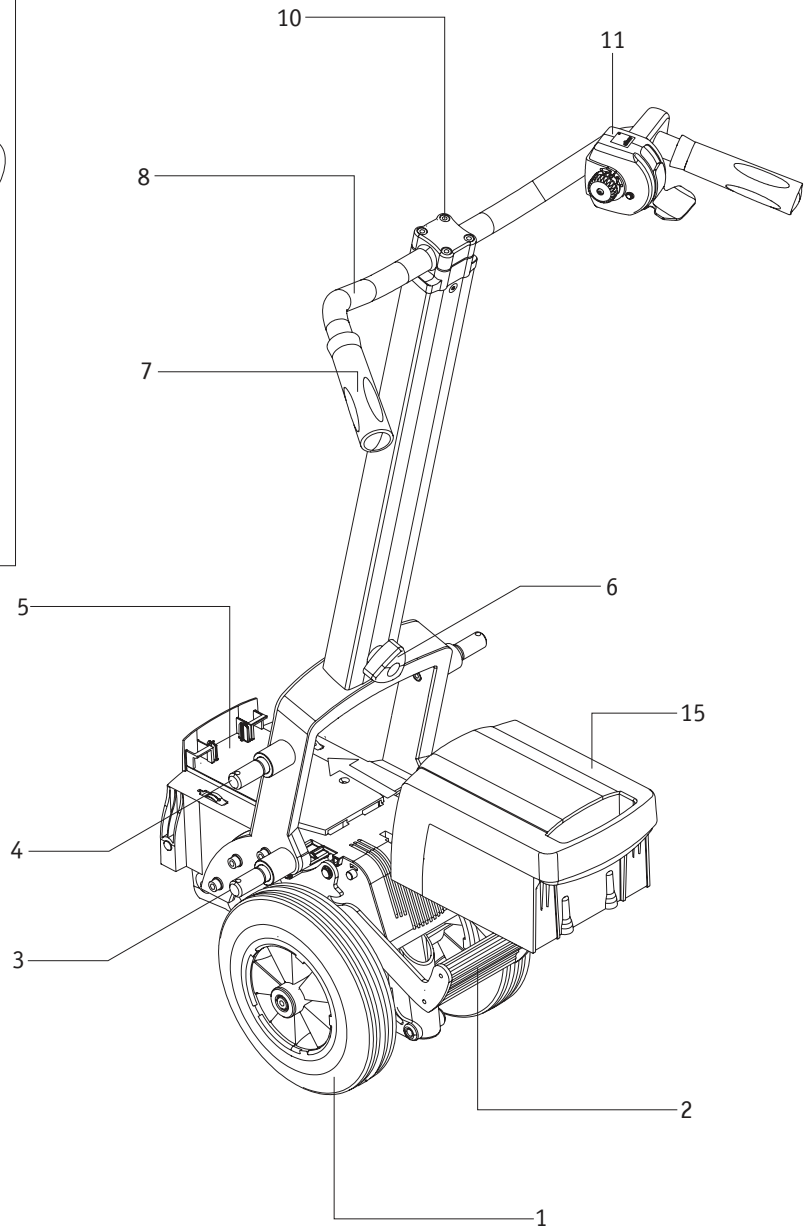
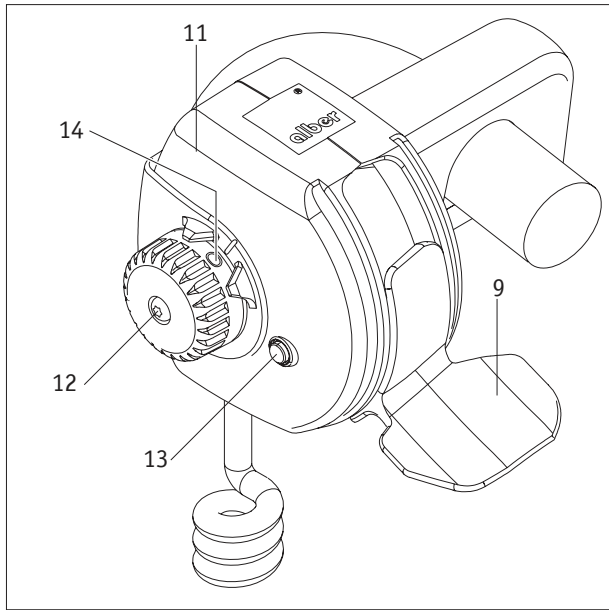

Content

1. Introduction	2
1.1 Important Safety Instructions – please take note	2
1.2 Purpose of viamobil	2
1.3 Permissible Operating Conditions / Points of Use	2
1.4 Standard Scope of Delivery	2
1.5 Technical Data	3
1.6 The most Important Elements at a Glance	4
2. Starting-up	5
2.1 Extending Drive Wheels	6
2.2 Activating Roll Operation	7
2.3 Fixing viamobil to the Wheelchair	8
2.4 Selecting speed at the control unit	10
2.5 Forward travel	10
2.6 Reverse travel	10
2.7 Traversing obstacles	12
2.8 Switching off driving mode	12
2.9 Retracting Drive Wheels	13
2.10 Removing viamobil from the Wheelchair	14
3. Rechargeable battery pack	15
3.1 Inserting Rechargeable Battery Pack into Drive Unit	15
3.2 Removing Rechargeable Battery Pack from Drive Unit	15
3.3 Charging Rechargeable Battery Pack	16
3.4 Replacing the Fuse in the Rechargeable Battery Pack	16
3.5 General Information on the Batteries Used	17
4. Storage	18
5. Transport	19
5.1 Dismantling viamobil into Components	19
6. Adjusting the rocker arm	20
7. Fault Indications	21
7.1 Continuous Light of LED Status Display	21
7.2 Blink Code of LED Status Display	21
7.3 What should be done if...	22
8. Anti-tippers	23
9. Tips on First-time Driving	24
10. Safety Instructions and Hazard Warnings	25
10.1 Safety Instructions	25
10.2 Obstacles	26
10.3 Danger Spots and Danger Situations	27
11. Support, Maintenance and Disposal	28
11.1 Charging Rechargeable Battery Pack	28
11.2 Cleaning	28
11.3 Disposal	29
11.4 Reuse	29
11.5 Maintenance	29
12. Warranty, Guarantee and Liability	30
12.1 Warranty for Defects	30
12.2 Service Life Guarantee	30
12.3 Liability	30

1. Introduction

1.1 Important Safety Instructions – please take note

viamobil is a pushing and braking assistance, which is to be exclusively used by a person accompanying the wheelchair occupant. The wheelchair occupant is on no account to personally operate the viamobil as a wheelchair electric drive.

For safety reasons viamobil is furthermore only to be operated by people, who

- have been instructed as to its operation
- are physically and mentally capable of operating this unit safely in all operating situations.

Instruction on how to operate the unit is an integral part of the scope of delivery and given after an appointment has been arranged with your specialist dealer or one of Alber's regional managers. No additional costs are incurred hereby.

Please contact your specialist dealer or one of Alber's regional managers if you are still not quite sure how to operate and handle the viamobil.

You can also get in touch with the Alber Service Centre on (telephone 0800-9096-250) in the event of any possible technical faults.

Please observe the specified values provided by the manufacturer of your wheelchair (i.e. maximum incline, air pressure in the wheels etc.) as well as the general operating instructions when operating the viamobil. Details on threshold values are on no account to be exceeded.

The viamobil should be switched off initially on safe terrain when mobile phone or similar device is used. Trips near strong electrical noise fields should also be avoided.

Operation of the viamobil could interfere with other facilities, such as checkpoint security systems in large department stores.



It is imperative that you avoid starting-up the viamobil prior to being instructed in how to operate it by an Alber regional manager or authorised specialist dealer!

1.2 Purpose of viamobil

viamobil is attached to a manual wheelchair as an add-on drive to support the attendant person of a wheelchair occupant when pushing and braking the wheelchair, thus enabling longer trips to be managed without becoming tired. Uphill, the electric motor of the viamobil delivers the power to push the wheelchair; downhill, the viamobil reliably maintains the preset speed and thus allows for the safe manoeuvring of downward sloping routes..

Make sure you become familiar with the safety instructions and hazard warnings in chapter 10 before starting off on your trip.

1.3 Permissible Operating Conditions / Points of Use

- Pay attention to the instructions on the permissible operating conditions in the instruction manual for your wheelchair, to which the viamobil is attached. Restrictions of permissible operating conditions (i.e. maximum climbing capability, maximum permissible obstacle height, maximum occupant weight etc.) also have to be observed when using viamobil!
- Avoid driving on surfaces that are not firm (i.e. on loose gravel, in sand, mud, snow, ice or through deep puddles of water).
- Pay attention to the safety instructions and hazard warnings in chapter 10.

1.4 Standard Scope of Delivery

- Hand grips
- Drive unit
- Battery charger
- Rechargeable battery pack
- Instruction manual
- Information on terms of guarantee
- etc.

Anti-tippers (see chapter 8) are also available as optional accessories.

1.5 Technical Data

Drive unit:	range up to 12 km(*)
Speed:	continuous up to max. 6 km/h (forwards) or max. 3 km/h (backwards)
Incline:	up to max. 10% incline on uphill slope / downhill slope (at 120 kg occupant weight)
Motor power rating:	200 Watt

Rechargeable battery pack

Battery packs:	2 x 12 Volt, 7.2 Ah, permitted for air transportation by IATA and DOT
Operating nominal voltage:	24 Volt
Operating temperature:	ambient temperature area (approx. -25°C to + 50°C)

Weight of components:

Rechargeable battery pack:	6.0 kg
Drive:	10.5 kg
Hand grips:	1.9 kg
Battery charger:	0.5 kg
Total weight:	18.9 kg

(*) The range varies according to the terrain the wheelchair is driven on and the prevailing driving conditions. The specified range can be attained with the optimum driving conditions (flat terrain, freshly charged batteries, ambient temperature of 20°C, smooth drive etc.).



The viamobil meets the EC guidelines for medical products 93/42/EWG .
Subject to changes in technology and design due to constant further developments.

Battery charger

Technical notices and instructions can be read in the instructions accompanying the battery charger.

1.6 The most Important Elements at a Glance

(for this, please open up the overview diagram on the book cover)

Chassis

Drive wheels	1
Pedal	2
Lower bolt	3
Upper bolt	4
Base carrier	5

Hand grips

Hand wheel	6
Handle	7
Handle bar handle	8
Clamping yoke	9
Clamping screw	10
Control Unit	11
Operating button	12
LED status display	13
Driving condition scale	14

Rechargeable battery pack

Rechargeable battery pack	15
Fuse 25 A	16
Fuse 3 A	17
Charger socket	18
Handle	19
Unlocking device	20

Wheelchair

Bracket	21
Upper receiver	22
Lower receiver	23
Lock	24
Adjusting collar	25

Battery charger

Charging plugs	26
----------------	----

Wheelchair anti-tippers

Anti-tipper	27
Fork	28
Receiver Shoe	29
Quickpin	30

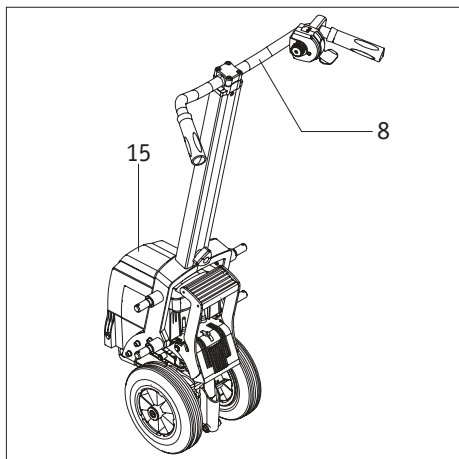



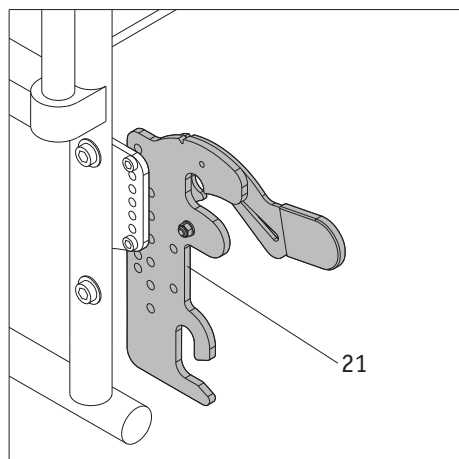

2. Starting-up

The viamobil is ready for utilisation when delivered to you by your specialist dealer. This means that

- a special bracket [21] has been fixed to the wheelchair on both sides as a receiver for the viamobil,
- the viamobil is completely assembled and the rechargeable battery pack [15] is inserted into the device,
- the viamobil handle bar [8] has been adjusted by your specialist dealer according to the requirements made by the user.



- 
Assembly of the bracket [21] on the wheelchair as well as the accompanying adjustments to the viamobil are only to be carried out by Alber or an authorised specialist dealer.
- 
You should regularly check whether the brackets [21] are still screwed tightly to the wheelchair. If the screw fittings have become loose or even become unscrewed, then please make sure that they are screwed down again by an authorised specialist dealer. Readjustments may be necessary.
- 
Alber manufactures brackets in various versions, i.e. as a complete component or comprising separate parts. Figures in this instruction manual may therefore deviate from the bracket mounted to your wheelchair.
- 
Pay attention to the instructions in chapter 9 (instructions on first-time driving) and chapter 10 (safety instructions and hazard warnings) prior to starting up your viamobil .

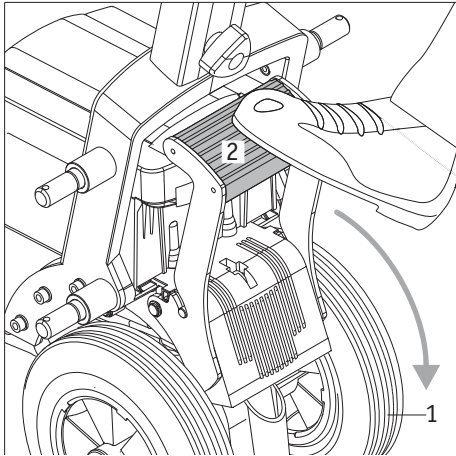

2.1 Extending Drive Wheels

- Use the forward section of your foot to move the pedal [2] downwards from its resting position .
- Press the pedal [2] down strongly with the forward section of your foot when in middle position; both drive wheels [1], which are still retracted at present, are therefore extended.
- If the wheels [1] are extended, you have to swivel the pedal [2] upwards again into its original resting position.



Swivel the pedal [2] back into its resting position after each utilisation!

Malfunctions could result if the pedal [2] is not swivelled back into the resting position.

viamobil's braking performance could also be influenced!!

6

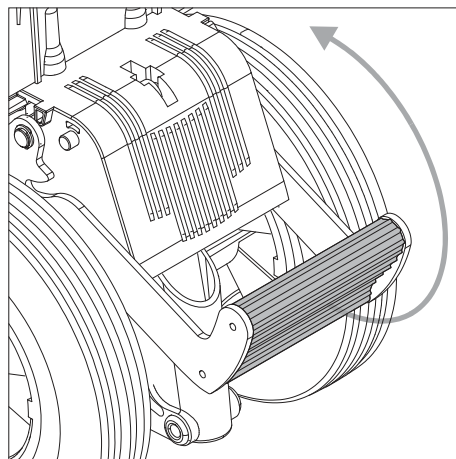
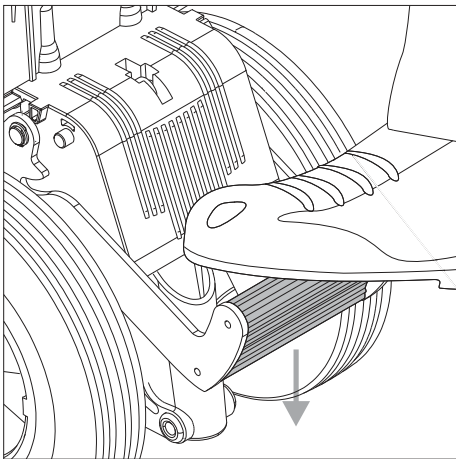

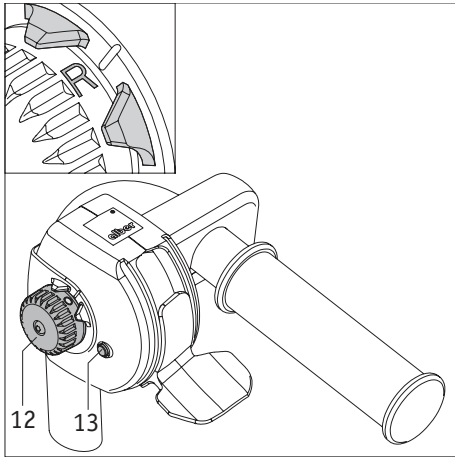

2.2 Activating Roll Operation

Your viamobil can be manually pushed without requiring the support of the motor when in so-called „roll operation“. This feature is solely intended for inserting and removing the viamobil underneath the wheelchair.

- Turn the operating button [12] into „R“ (Roll) position.
- Wait approx. 2 seconds until the brakes unlock. You will be able to hear a clicking sound.
- The LED status display [13] lights up permanently, the viamobil can be pushed (without the support of the motor).



The electronics on the viamobil have determined a fault if the LED status display blinks and is not permanently lit up. Switch off viamobil and then restart.

Please observe instructions regarding this matter in chapter 7.2.



Never activate roll operation when driving on uphill or downhill slopes. The wheelchair could unintentionally start moving due to carelessness!



For safety reasons the brakes are temporarily activated if pushing or rolling is deemed as too fast.

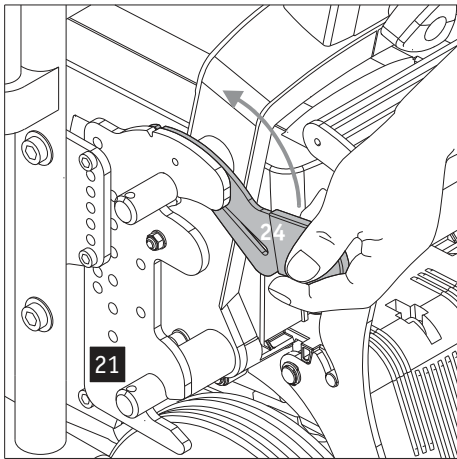

2.3 Fixing viamobil to the Wheelchair

The wheelchair occupant should sit in the wheelchair in order to facilitate the fixing of viamobil. The lever brakes on the wheelchair also have to be pulled in order to prevent unintentional rolling away.

If you haven't done so:

- check that the drive wheels of your viamobil are extended (see chapter 2) and roll operation has been activated (see chapter 2.2).
- Pull the lock [24] upwards on the bracket [21] on both sides until it cannot go any further.



If Alber anti-tippers are attached to your wheelchair (see chapter 8, anti-tippers) then they have to be removed to be able to fix the viamobil to the wheelchair. The anti-tippers have to be reattached (see chapter 8) when the viamobil is securely connected to the wheelchair.

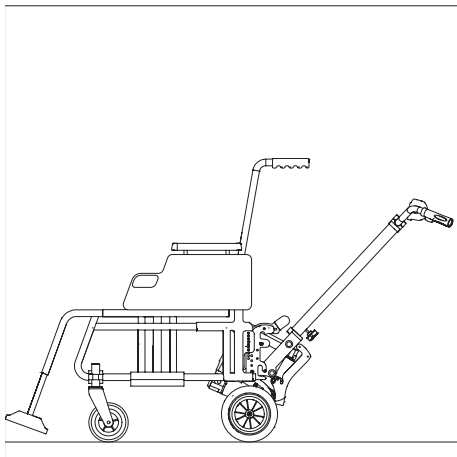

- Push your viamobil from behind underneath the wheelchair, whereby the lower bolt [3] is initially inserted into the lower receiver [23] of the bracket on both sides.

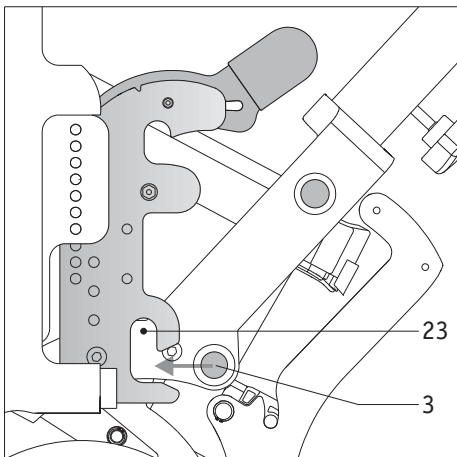

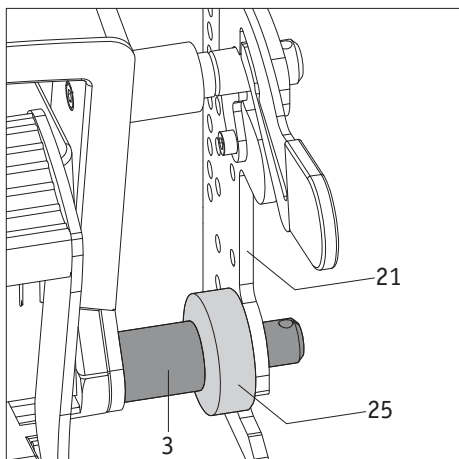

- When inserting pay attention that adjusting collars [25] may be mounted to your viamobil within the bracket [21]!

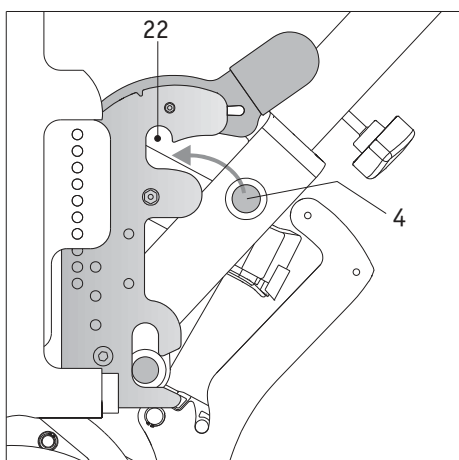

- If the lower bolt [3] is in the lower receiver [23], the viamobil has to be tilted forwards as shown in the figure so that the upper bolt [4] is inserted into the upper receiver [22] of the bracket on both sides.

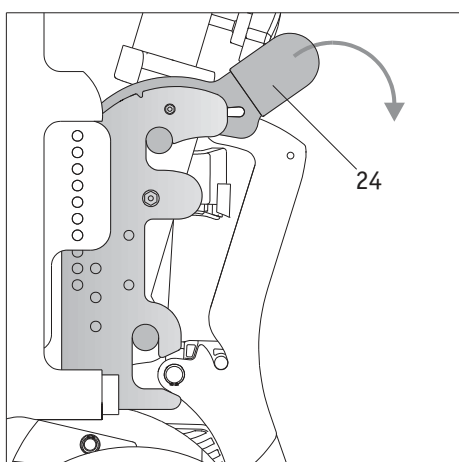

- If both bolts [3 and 4] are in their receivers [22 and 23] then you have to push down hard on the lock [24] on both sides in order to secure the viamobil to the wheelchair.

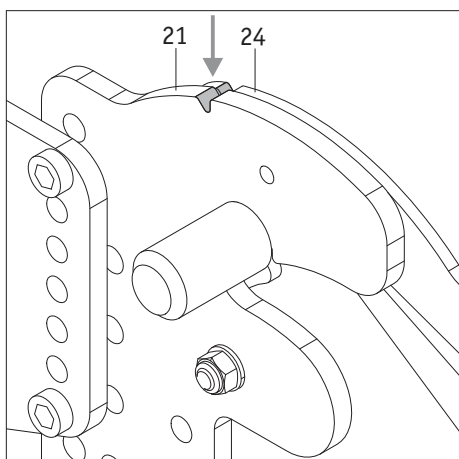

**Your viamobil can only be started up when the bolts are correctly located in their receivers and secured by locks on both sides of the wheelchair.
The bolts are only correctly secured when the notches of bracket [21] and lock [24] are in alignment to each other.**

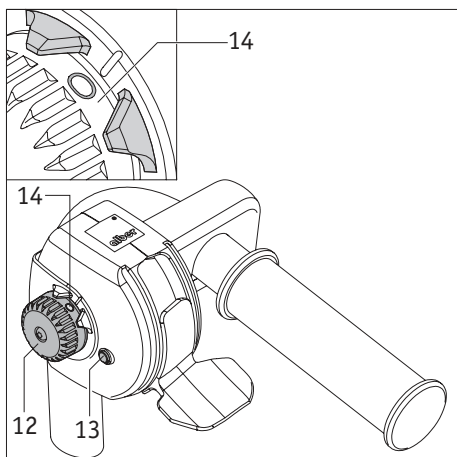

2.4 Selecting speed at the control unit

The scale positions [14] on the button [12] are assigned as follows:

- Position "0": the viamobil is switched off; the LED status indicator [13] is off.
- Positions "1" to "6": preset speed (continuously adjustable from "1" = 1 km/h to "6" = 6 km/h); the LED status indicator [13] is on.
- Position "R": the brake of the viamobil is disabled and the drive wheels are set to idle rolling mode. The LED status indicator [13] is on.

To select the speed at which you wish to operate the wheelchair, turn the button [12] to the respective position (1-6).

To switch off the viamobil, turn the button [12] to position "0".

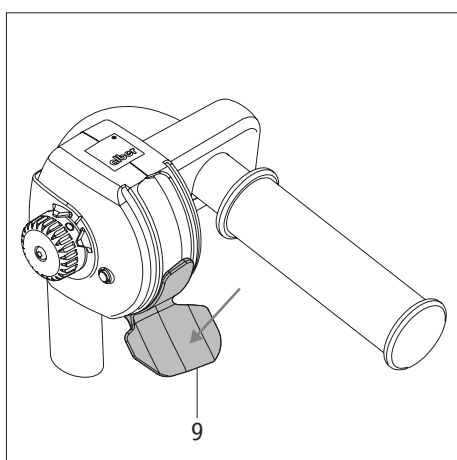

2.5 Forward travel

- Hold the viamobil with both hands by the handles of the wheelchair.
- Push the driving lever [9] slowly down to the stop, using your thumb.

As long as the driving lever [9] is pushed down, the viamobil drives the wheelchair forward. When the driving lever [9] is released, it automatically returns to its initial (centre) position. The viamobil is thus stopped and the brakes are applied.

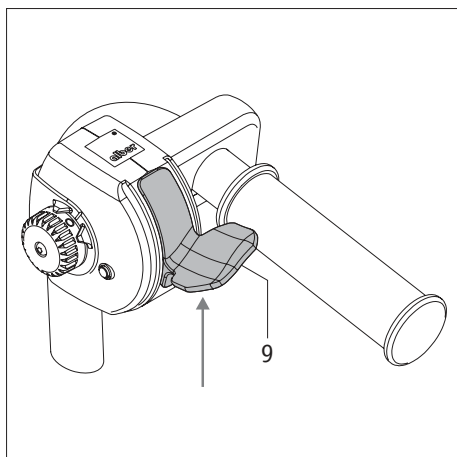

2.6 Reverse travel

- Hold the viamobil with both hands by the handles of the wheelchair.
- Push the driving lever [9] slowly up to the stop.

As long as the driving lever [9] is pushed up, the viamobil drives the wheelchair backwards. When the driving lever [9] is released, it automatically returns to its initial (centre) position. The viamobil is thus stopped and the brakes are applied with an audible click.



When starting the viamobil for the first time, operate it at minimum speed (set speed select button to position „1“) and familiarise yourself with the drive behaviour of the device. You can then gradually increase the speed and operate the device in forward and reverse mode. After a few minutes, you will have developed a feel for the safe operation of the viamobil.



The viamobil is protected against inadvertent drive actuation. It is therefore not possible to first actuate the driving lever [9] and then switch on the viamobil.

If the driving lever is actuated before the viamobil is switched on, the device is blocked and the LED status indicator [13] flashes 6 times (for fault codes, see chapter 7.2).

In this case, you must switch off the viamobil by turning the button [10] to position „0“ and then switch it on again.



While operating the add-on drive, keep an eye on the LED status indicator [13] for possible fault signals (see also chapter 7.2). If the indicator flashes at uniform intervals during driving, the battery pack of the viamobil needs to be recharged. Terminate your trip with the viamobil as soon as possible. If this is not possible, switch off the viamobil as soon as this is possible (see chapter 2.8) and retract the drive wheels (see chapter 2.9). You can then push the wheelchair without the assistance of the add-on drive.



When driving along bends, turning the wheelchair or driving uphill or downhill, the centre of gravity of the wheelchair might be shifted so that there is a risk that the wheelchair might tip over to the side. Therefore proceed with extreme care and reduce the speed of the add-on drive!



For safety reasons, the brakes are automatically applied if the wheelchair is moving too fast (pushed or rolling freely).



Never secure the driving lever [9] in a position using a strap or similar object. Only operate the driving lever with your thumb.



Do not attach bags or similar objects to the handlebars of the wheelchair or to the driving lever [9], as this could prevent the lever from returning to its neutral position.

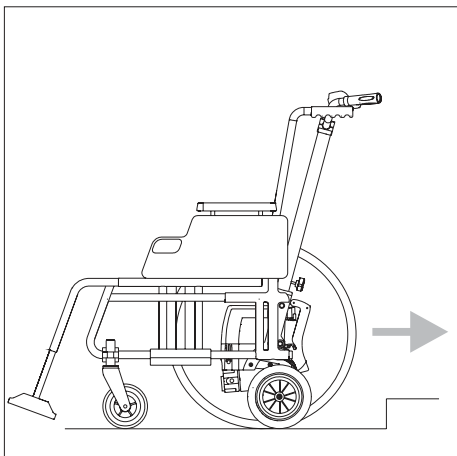

2.7 Traversing obstacles

Obstacles higher than 3 cm (such as kerbs) must be traversed backwards with the viamobil switched off.

- Retract the drive wheels [7] (see chapter 2.9).
- Turn the button [12] to position “R” to set the viamobil to idle rolling mode. The brake of the viamobil is disabled and the drive wheels are set to idle rolling mode. The LED status indicator [13] is constantly on.
- Lift the wheelchair by its handles and pull it backwards over the obstacle.

After having traversed the obstacle:

- Lower the drive wheels [7] again (see chapter 2.1).
- Select the desired speed at the control unit [11] (see chapter 2.4) and continue your trip.

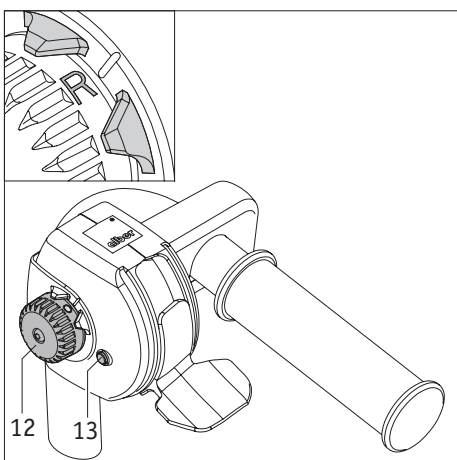

Never switch to idle rolling mode when driving up or down a slope. There is a risk that the wheelchair could be inadvertently set in motion!



When climbing or descending across kerbs, observe the maximum obstacle height specified by the wheelchair manufacturer.

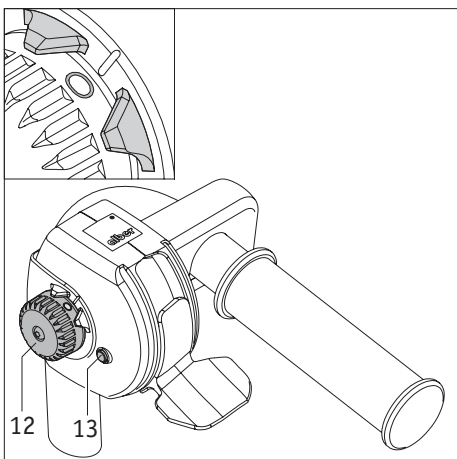

2.8 Switching off driving mode

To switch off the driving mode, turn the button [12] to position “0”. The viamobil is now switched off and the LED status indicator [13] is off.



When not in use, switch off the viamobil to prevent unnecessary discharge of the battery pack.

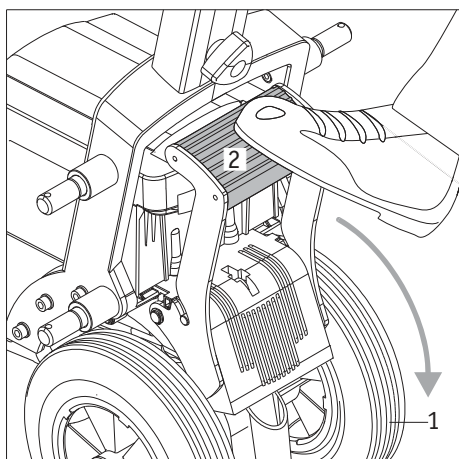

2.9 Retracting Drive Wheels

Both drive wheels [1] can be retracted if the wheelchair should be moved without the motorised support of the viamobil. Go ahead as follows to carry out this procedure:

- if you haven't already switched off the viamobil, proceed to switch it off (see chapter 2.7).
- Use the forward section of your foot to move the pedal [2] downwards from its resting position .
- Press the pedal [2] down strongly with the forward section of your foot when in the middle position; both wheels [1], which are still extended at present, are therefore retracted.
- If the wheels [1] are retracted, you have to move the pedal [2] upwards again into its original resting position.



Swivel the pedal [2] back into its resting position after each utilisation!

Malfunctions could result if the pedal [2] is not swivelled back into the resting position.

viamobil's braking performance could also be influenced!!

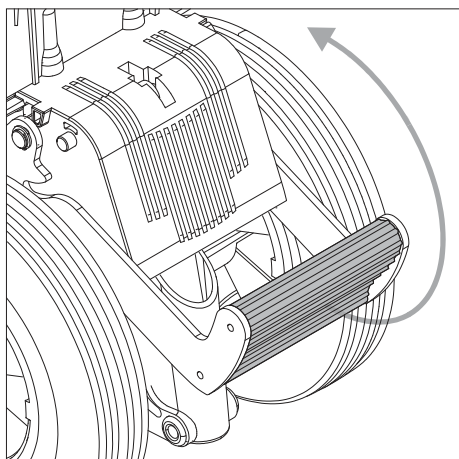
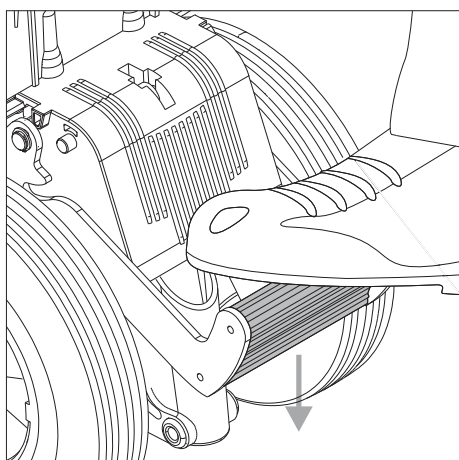

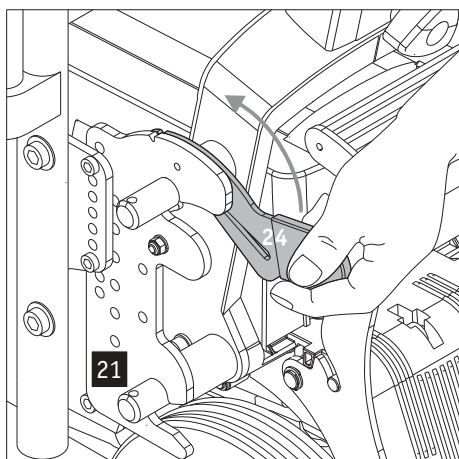

2.10 Removing viamobil from the Wheelchair

Once attached to the wheelchair, your viamobil generally remains assembled. If the device has nevertheless to be removed from the wheelchair at all, especially for transport purposes, then this can be done quickly and easily. The wheelchair occupant should sit in the wheelchair in order to facilitate the removal of viamobil. The lever brakes on the wheelchair also have to be pulled in order to prevent it from unintentionally rolling away.

If you haven't done so:

- check that the drive wheels of your viamobil are extended (see chapter 2) and roll operation has been activated (see chapter 2.2).
- Pull the lock [24] upwards on the bracket [21] on both sides until it cannot go any further.
- Move the pedal [2] from its resting position into the middle position (see figure).
- Press the pedal [2] down strongly with the forward section of your foot when it is in the middle position and at the same time remove the viamobil from the brackets.

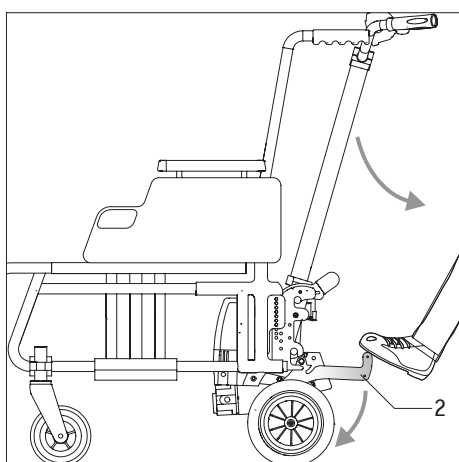

If Alber anti-tippers are attached to your wheelchair (see chapter 8, anti-tippers) then they have to be removed to be able to remove the viamobil from the wheelchair. The anti-tippers have to be reattached (see chapter 8) as soon as the viamobil has been removed from the wheelchair.

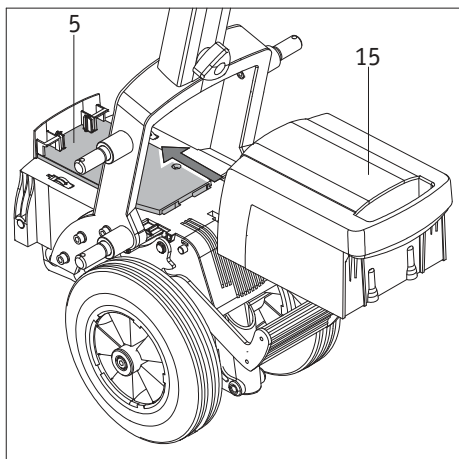

3. Rechargeable battery pack

3.1 Inserting Rechargeable Battery Pack into Drive Unit

- Place the rechargeable battery pack [15] on the base carrier [5] of the drive unit and insert.
- While inserting, press the rechargeable battery pack [15] slightly downwards just before
- reaching the stop position on the base carrier [5] in order to let it engage into the lock.
- Check that the rechargeable battery pack is correctly installed [15] by attempting to remove it from the drive unit again without operating the unlocking device [20]

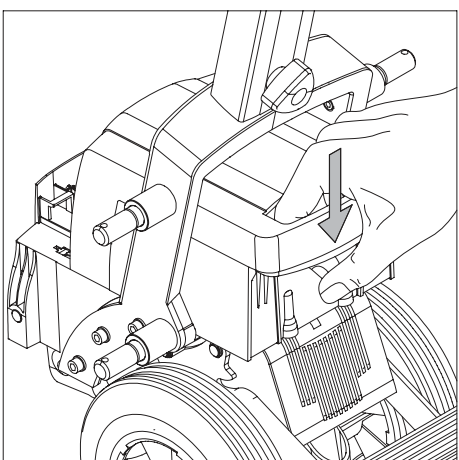

The viamobil is only ready for use when the rechargeable battery pack [15] is correctly inserted in the base carrier [5].

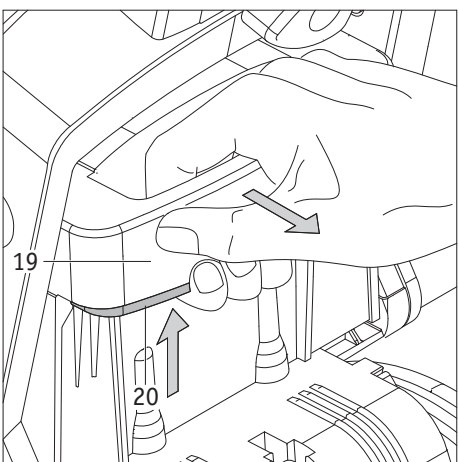

3.2 Removing Rechargeable Battery Pack from Drive Unit

The rechargeable battery pack has to be removed from the drive unit in order to charge the batteries or for transport purposes.

- Press the unlocking device [20] mounted on the handle [19] upwards and at the same time remove the rechargeable battery pack from the drive unit.

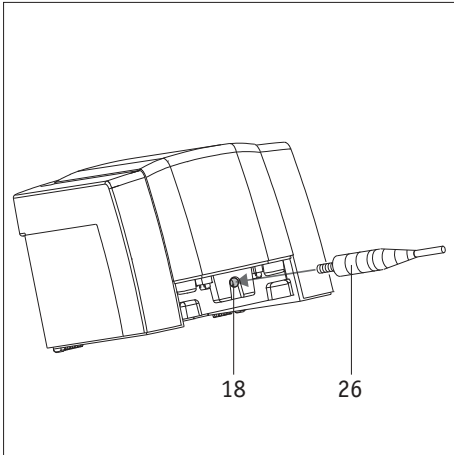

3.3 Charging Rechargeable Battery Pack

- Remove the rechargeable battery pack [15], as described in chapter 3.2, from the drive unit.
- Insert the plug [26] for the mains battery charger into the charger socket [18] on the back of the rechargeable battery pack.



Pay attention to the instructions in the operating instructions accompanying the battery charger when charging the rechargeable battery pack.



A suitable voltage converter is necessary for charging the rechargeable battery pack when driving in a car. This can be obtained from your regional electrical supplier.

3.4 Replacing the Fuse in the Rechargeable Battery Pack

- Remove the rechargeable battery pack [15], as described in chapter 3.2, from the drive unit.
- Remove the defective fuse [16 or 17] from the rechargeable battery pack.
- Replace the defective fuse with a new one you have received from your health care specialist.
[16] = fuse 25 Ampere
[17] = fuse 3 Ampere



**The reason could be a defect on the viamobil if fuses have to be replaced more often.
In such cases please get in touch with your specialist dealer or the Alber Service Centre regarding a technical inspection of your viamobil.**

3.5 General Information on the Batteries Used

The batteries of your viamobil are maintenance-free and rechargeable. Their service life mainly depends on the charging / discharging cycles. Their service life increases by taking correct care of the batteries (recharging).

- Avoid completely discharging the rechargeable battery pack. You should therefore recharge the rechargeable battery pack of the viamobil after each partial discharge, i.e. after every utilisation.
- Lead-acid batteries are subject to a so-called self-discharge. For this reason the viamobil rechargeable battery pack should always be connected to the battery charger at all times whenever possible. Overcharging the rechargeable battery pack is not possible due to the charge mechanism.
- If the rechargeable battery pack is stored for a longer period of time (without being charged), it experiences a loss in capacity. Full capacity is usually available again after a few charging / discharging cycles.
- Electrolyte fluid can escape if the rechargeable battery pack is not handled properly. Injuries to the skin or damage to clothing could be therefore caused.
- If the electrolyte fluid comes into contact with a person's skin or eyes, rinse immediately with clear cold water and consult a doctor.
- Do not expose the rechargeable battery pack to fire or burn the rechargeable battery pack. This could result in the rechargeable battery pack exploding.
- Do not short-circuit the rechargeable battery pack's contacts. A short circuit results in extremely high artificial currents which could damage the rechargeable battery pack or the viamobil.
- After the service life of the battery has expired, it can be returned to Alber or an Alber specialist dealer for professional disposal.



The rechargeable battery pack of your viamobil can be discharged and charged in any user-defined situation. It is so rated as being as safe as dry cells and permitted for air transportation by IATA and DOT.

4. Storage

- Store your viamobil on an easy-to-clean mat if possible. If your viamobil is parked without the wheelchair, it should be propped up against a wall etc.
- If your viamobil is not started up for a longer period of time, the device - and especially the rechargeable battery pack - is to be stored in a dry environment, preferably at room temperature (+15 °C to 25 °C).
- The rechargeable battery pack should be permanently connected to the battery charger, if possible, if your viamobil is only being stored and not started up. If this is not possible, then the viamobil should be connected to the supplied battery charger at intervals of one month and completely recharged. This will ensure that your viamobil is ensured functional capability even over a longer period of storage.
- The batteries used are dry cells, which are leak-proof when handled correctly and maintenance-free except for the above-mentioned conservation of charge. The rechargeable battery pack should be preferably stored as in the installation position on the viamobil. Further instructions on the batteries used can be found in chapter 3.5
- If the viamobil is parked with the wheelchair for a longer period of time, the drive wheels should be lifted from the ground by operating the pedal (see chapter 2.8).
- If your viamobil is stored for a longer period of time, it should be switched on for a short time every month if possible and moved a few metres forwards and backwards so as to prevent the brake from blocking, for example, due to the long down-time.

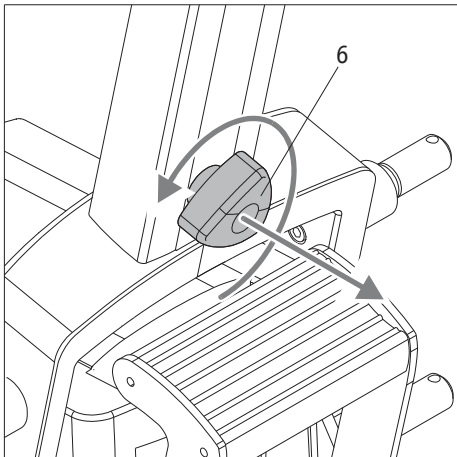

5. Transport

5.1 Dismantling viamobil into Components

Your viamobil can be dismantled into individual components for transport purposes. Go ahead as follows to carry out this procedure:

- Remove the rechargeable battery pack (see chapter 3.2).
- Loosen and remove the hand wheel [6].
(Do not lose the hand wheel during transport!)

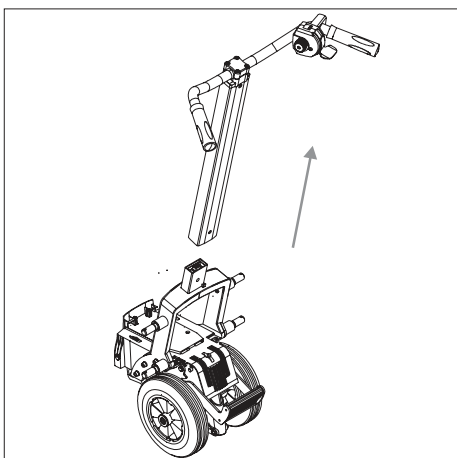

- Remove the hand grips from the drive unit, as shown in the figure.

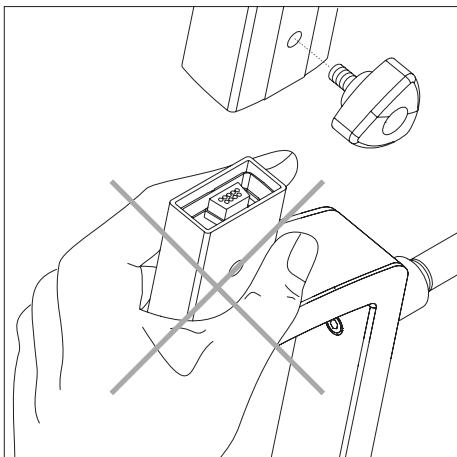

- Assembly must be completed in reverse order.



Caution Danger of crushing!
Do not touch the area near the mechanical guide during assembly of the hand grips and drive unit.

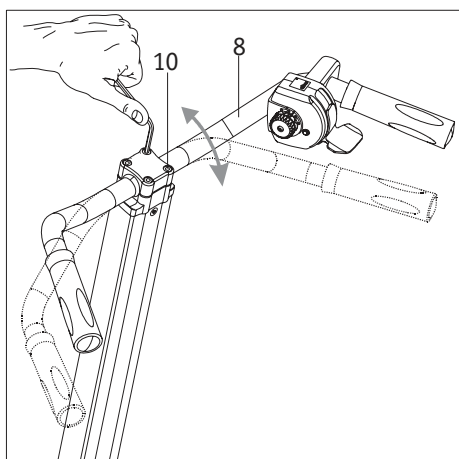

6. Adjusting the rocker arm

The delivery of the viamobil, the assembly of the individual components, and the attachment to the wheelchair is performed by your specialist dealer. The specialist dealer will adjust the device and, in particular, the rocker arm [8] to the size and ergonomic needs of the operator.

If the rocker arm [8] needs to be readjusted, for example for a different operator, you can ask your specialist dealer or make the adjustment yourself following these steps:

- Loosen the screw [10] using a hexagon socket screw key (spanner size 6mm).
- Rotate the rocker arm [8] to a position that is comfortable for the operator.
- After reaching the desired position, firmly retighten the screw [10] to a torque of 5.5 Nm.

Use the hexagon socket screw key with a spanner size of 6 mm again.

If the position to which the rocker arm [8] can be set is not low enough, you can completely remove the rocker arm and refit it after turning the rocker arm by 180 degrees. This allows you to lower the operating position. As this also requires the removal and reinstallation of the control unit, we recommend that you entrust your specialist dealer with this procedure.





7. Fault Indications

7.1 Continuous Light of LED Status Display

A continuous light on the LED status display [13] usually signals that the viamobil is operating properly and failure-free. If the rechargeable battery pack is almost completely empty, its residual capacity is no longer sufficient to activate a blink code. In this case the LED display also shows a continuous light until the rechargeable battery pack is completely discharged. In this case you should immediately recharge the rechargeable battery pack.

7.2 Blink Code of LED Status Display

Your viamobil reports malfunctions to the LED status display [13] via a sequence of blinks. Each blink sequence has a different meaning such as:

LED Blink Code	Cause of Malfunction	Remedy
 (1x blinking light)	The rechargeable battery pack of the viamobil is empty.	Recharge your rechargeable battery pack as soon as possible.
 (3 x blinking light)	The rechargeable battery pack has been charged by the motor on a downhill drive until it has reached its capacity limit.	Switch off viamobil and then restart (see chapter 2.4). Continue your downhill trip with the slowest speed possible. Avoid going on a longer steep downhill drive with a full rechargeable battery pack.
 (6 x blinking light)	The locking device to prevent unintentional drive function activation has noticed that you have actuated the driving lever while switching on the viamobil.	Switch the viamobil off. Then switch on the viamobil again without actuating the driving lever.
 (9 x blinking light)	Internal Fault	Switch off viamobil and then restart (see chapters 2.4 and 2.7). No further driving is possible if the fault indication continues. Please get in contact with your specialist dealer or the Alber Service Centre (see inside cover flap for more details).



The electronics has determined a defect on the viamobil, if a blink code is displayed which is different to those mentioned in the above-mentioned table. Further driving is no longer possible in such cases. Please get in contact with your specialist dealer or the Alber Service Centre (see inside cover flap for address).

7.3 What should be done if...

Further malfunctions can, if necessary, be eliminated as follows:

Your viamobil reports malfunctions to the LED status display [13] via a sequence of blinks.

Each blink sequence has a different meaning such as:

What should be done if...	Remedy	Contact
your rechargeable battery pack can no longer be recharged.	This fault can only be eliminated at the factory.	your specialist dealer
your viamobil can no longer be switched on.	Check - whether the rechargeable battery pack has been charged - whether the fuses in the rechargeable battery pack are perhaps defective.	
your viamobil can no longer be switched on although the rechargeable battery pack is charged and its fuses are in working order.	This fault can only be eliminated at the factory.	your specialist dealer
the viamobil suddenly stops.	Switch off viamobil and then restart. If you get no reaction the device is defective and has to be sent into the factory for repairs.	your specialist dealer
the viamobil is audibly running, but makes no movement	Check whether the drive wheels are on the ground or perhaps still unintentionally retracted (see chapter 2.8).	



No further driving is usually possible if another malfunction occurs, which is not listed in the table above. Please get in contact with your specialist dealer or the Alber Service Centre (see inside cover flap for more details).

8. Anti-tippers

Alber anti-tippers are only available as an optional accessory for your viamobil, because most wheelchairs are already equipped with anti-tippers as part of their standard equipment.

The forks [28] required for driving are already attached to the bracket if anti-tippers are ordered and delivered together with the viamobil.

An authorised health care specialist should be able to get anti-tippers attached to your wheelchair at any time, should you want to have them installed at a later date.



It is strongly recommended that anti-tippers are mounted to your viamobil or wheelchair for drives on flat surfaces!

The use of paired anti-tippers is mandatory on drives on uphill slopes over 8%. Please note that certain wheelchair models must always be equipped with Alber anti-tippers. This requirement is based on the results of combined tests carried out for the compilation of the bracket list.

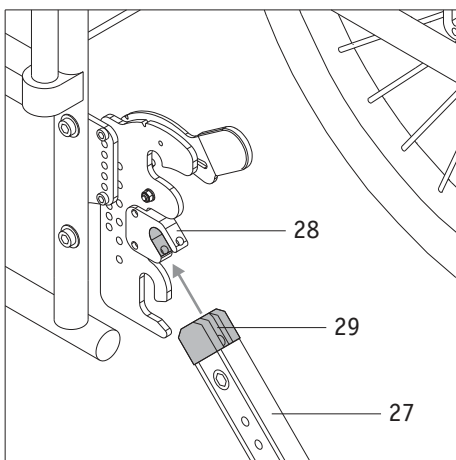

- Insert the receiver shoe [29] on the anti-tipper [27] into the fork opening [28].

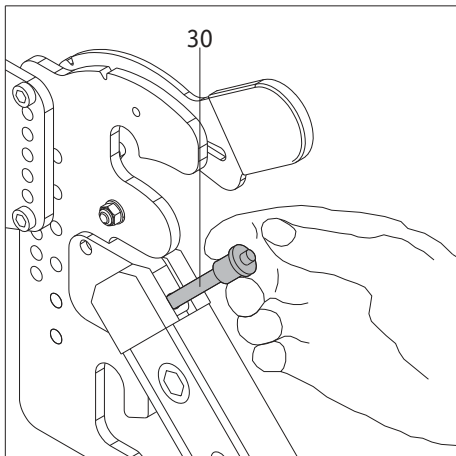

- Press the unlocking device in the centre of the quickpin [30] with your thumb and completely insert through the fork [28] and the receiver shoe [29] inside the fork until it cannot go any further.
- Check that the quickpin [30] is fitted securely in the fork [29].
- Remove the anti-tippers in reverse order.



The quickpin [30] should not be able to be removed without pressing the unlocking device!

9. Tips on First-time Driving

Your viamobil has been prepared by Alber or your specialist dealer and delivered to you. We would therefore like to subsequently give you two tips on first-time driving.

- Both drive wheels of the viamobil are approx 2 cm above the ground when in resting position. You thus have the opportunity of moving the wheelchair without the help of viamobil.
- Use the lowest possible speed (operating button for speed selection on setting „1“) on the viamobil when driving for the first time and become familiar with the driving properties of the viamobil. You can then gradually increase the speed and drive both backwards and forwards. You should get a feeling for driving your viamobil safely after just a couple of minutes.

10. Safety Instructions and Hazard Warnings

The following instructions are to be implicitly observed in order to guarantee the secure utilisation of your viamobil.

10.1 Safety Instructions

Pay attention to the following before driving:

- the viamobil should only be fixed to wheel chairs, which have been cleared by the Ulrich Alber GmbH company for this purpose.
- Assembly and alteration to the brackets for the viamobil are only to be carried out by the Ulrich Alber GmbH company or by a health care specialist authorised by Alber.
- It is imperative that you pay attention to the instruction manual for the wheelchair when using the viamobil.
- The permissible peak load of the wheelchair is reduced by the weight of the viamobil (approx. 25 kg).
- The viamobil is designed to be used on self propelling wheelchairs and transit chairs and must be operated by the attendant only (under no circumstances must any modification be done to the viamobil that allows the person sitting in the chair to be in charge of the controls of the viamobil). The person pushing must be able to support the wheelchair and wheelchair occupant in the event of it tilting backwards or to the side.
- It is strongly recommended that anti-tippers are mounted to your viamobil or wheelchair! The use of paired anti-tippers is mandatory on uphill slopes over 8%.
- The lever brakes on the wheelchair, to which the viamobil is attached, have to be arranged so that the person pushing is able to reach them easily.
- Check the condition of the drive wheels before setting off on every drive. You are no longer permitted to operate the viamobil if the tyres have reached their wear limit.
- Check whether the control unit [11] is firmly seated on the rocker arm [8] prior to each use.
- If you discover that the control unit is only loosely connected to the rocker arm, have your authorised specialist dealer reinstall it properly.
Also check the distance between the driving lever [9] and the handle [7] in this regard. As they must not come into contact with one another, driving lever and handle should be at least 5 mm apart.
- Ensure that the air pressure in the wheels of the wheelchair correspond with the specifications of the wheelchair manufacturer.
- The viamobil should be checked and serviced every two years by Alber or your specialised dealer (see chapter 11.3).

Pay attention to the following when driving your viamobil:

- You should know how to handle the drive add-on on flat surfaces before taking the viamobil on uphill or downhill slopes.
- Always turn the operating button for the speed selection to the position displaying the lowest speed possible when starting up and gradually increase the speed to the required walking speed.
- It is not permitted to drive on uphill or downhill slopes with an incline over 10%. The max. permissible incline as stated by the wheelchair manufacturer is under no circumstances to be exceeded.
- Set the operating button for the speed selection to a speed which is not faster than a comfortable walking speed for the person pushing, especially before manoeuvring inclines.
- Uphill and downhill slopes should never be manoeuvred in roll operation mode.
- Never back up to steps or drops when the drive add-on is switched on.
- If the viamobil is switched on, every impulse on the handle bar is transferred into a driving command. Every unwanted impulse should therefore be eliminated if possible. Switch the viamobil off when stopping or waiting in front of potential danger spots (i.e. while waiting at traffic lights, uphill and downhill slopes or ramps of all kinds) and remove your hands from the handle bar.

- Do not attach any objects (carrier bags etc.) to the handle bar of your viamobil! These could cause unwanted driving impulses.
- Keep a sufficient distance to the kerb when driving on pavements (if possible at least one wheelchair width).
- Always cross the kerb in backwards drive with the viamobil switched off. The wheelchair is to be lifted on its handles (not by the handles of the viamobil). Pay attention to the maximum climbing height as specified by the manufacturer of the wheelchair when driving over kerbs.
- Avoid driving on surfaces that are not firm (i.e. on loose gravel, in sand, mud, snow, ice or through deep puddles of water).
- Never leave your viamobil unsupervised - when switched on or off. If this can, however, not be avoided, the removal of the rechargeable battery pack protects against the unauthorised use of your viamobil.
- The drive of your viamobil may heat up during longer trips. You should therefore avoid touching the drive directly after taking out your viamobil (i.e. when loading the viamobil into the car).
- The performance of the viamobil can be influenced by electro-magnetic fields created, for example, by mobile phones. The drive add-on is therefore to be switched off if mobile phones are used in the direct vicinity of the wheelchair.
- The viamobil could interfere with other facilities, such as checkpoint security systems in large department stores.

Pay attention to the following after driving your viamobil:

- Switch the viamobil off immediately if you are not using it in order to prevent a driving impulse from being unintentionally triggered through contact with the handle bar or to stop the battery from self-discharging.
- Recharge the rechargeable battery pack of your viamobil after every drive if possible.
- Only park the wheelchair and the viamobil in dry and secure places. Never allow moisture or liquids to enter the viamobil or its battery pack and control unit.

10.2 Obstacles

Obstacles over 3 cm in height like, for example, kerbs, should only be manoeuvred in backwards drive.

- For this, switch the operating button of your viamobil to the setting „ROLL“, lift the drive wheels off the ground by operating the pedal (see chapter 2.8) and back up towards the obstacle.
- Pull the wheelchair backwards over the obstacle by using the wheelchair push handles on the wheelchair, but never use the handles of the viamobil to carry out this procedure.
- The drive wheels can then be released again by operating the pedal, the viamobil is once again set to the required driving speed by means of the operating button and you can continue driving.



Pay attention to the instructions in the instruction manual for the wheelchair regarding the maximum obstacle height that can be manoeuvred!

10.3 Danger Spots and Danger Situations

The user of the viamobil independently decides on which routes to utilise by taking into account his driving skills and physical abilities.

He is to check the viamobil for worn-down or damaged tyres as well as ensure the state of charge of the batteries and determine whether the control elements are in working order prior to driving.

These safety inspections as well as personal driving skills are especially important in regard to the following danger spots, the manoeuvring of which are at the discretion of the person pushing the viamobil:

- quay walls, landing stages, paths and locations on watercourses, unsecured bridges and dams.
- narrow paths, inclines (i.e. ramps and driveways), narrow paths on a slope, mountain paths.
- narrow and / or steep downward / sloping paths on main roads or near precipices.
- Icy or snow-covered roads or roads covered in leaves.
- Ramps and lifting gear on cars.



Uphill or downhill slopes with a maximum incline of 10% can be manoeuvred with the viamobil. Prerequisites are proper tread patterns, correct air pressure in the wheelchair wheels, unobjectionable ground conditions and maximum loading of 120 kg.

There is an increased tendency towards tilting to the side when on winding roads or when reversing on uphill or downhill slopes due to the shift of balance. These driving manoeuvres should be carried out with great care and only at low speeds! Extreme care should be taken when crossing main roads, crossings and level crossings. Never cross over any tracks or rails in streets or on level crossings when your wheelchair is parallel to the tracks or rails, because the wheels could otherwise perhaps get stuck in them.

Great care should be taken when driving on ramps or using lifting gear on cars. The viamobil is to be switched off and the handle bar let go of during the lifting or lowering procedure on the ramp or lifting gear. The hand brakes also have to be pulled on the wheelchair. This prevents the wheelchair from rolling away due to, for example, unintentional driving commands.

The tyres do not adhere so well to the surface if there is wetness on the ground; there is increased danger of skidding. Adjust your driving behaviour accordingly.

11. Support, Maintenance and Disposal

11.1 Charging Rechargeable Battery Pack

Your viamobil consumes energy every time it's used. You should never completely deplete the reserves in your rechargeable battery pack, because this can become damaged if done on a continuing basis. It is recommended that you recharge the rechargeable battery pack after every use whenever possible.

Only use the Alber mains battery charger supplied with the viamobil for charging the rechargeable battery pack. This switches itself off automatically as soon as the rechargeable battery pack is charged. It is therefore not possible to overcharge the rechargeable battery pack.

Also see chapter 3.5 for further instructions on the rechargeable battery pack

11.2 Cleaning

Only use commercially available cleaning fluids, which are used in households for all cleaning procedures.

- Drive unit, hand grips and rechargeable battery pack should only be rubbed down with a damp (not wet) cloth.
- The contacts on the rechargeable battery pack and on the base plate should be cleaned regularly with a cloth soaked in cleaning spirits.
- When using Alber anti-tippers, the receivers of the Alber anti-tippers should be cleaned every two months with a damp (but not wet) cloth.
- The bracket attached to the wheelchair is to be cleaned with a damp (but not wet) cloth.
- The drive wheel should be regularly cleaned to get rid of any dirt. This is best carried out with compressed air or a dry brush.

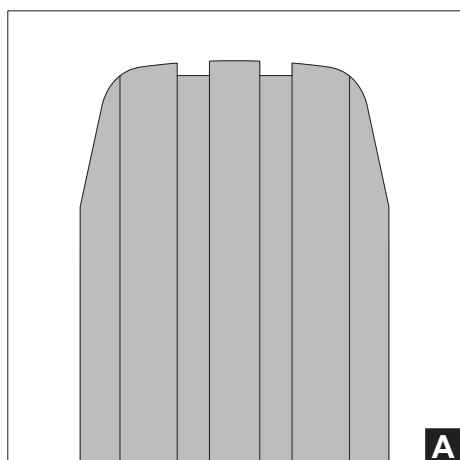

Your viamobil is an extremely low-maintenance device. No part of the drive is subject to noteworthy wear and tear with the exception of the tyres. The tyres are not to be used if they have reached their wear limit in order to be able to safely utilise the drive and braking power of your viamobil at all times.

A new tyre (see fig. A) boasts a prominent tread pattern and therefore guarantees the perfect pressure as well as optimum driving properties.

If the tyre of your viamobil is worn down (see fig. B), then the tread and the lateral radii [R] are no longer recognisable. The diameter [X] of the tyre is now 194 mm and has to be replaced immediately, because there may no longer be sufficient pressure on the ground.

Please contact your specialist dealer straightaway regarding a replacement tyre.

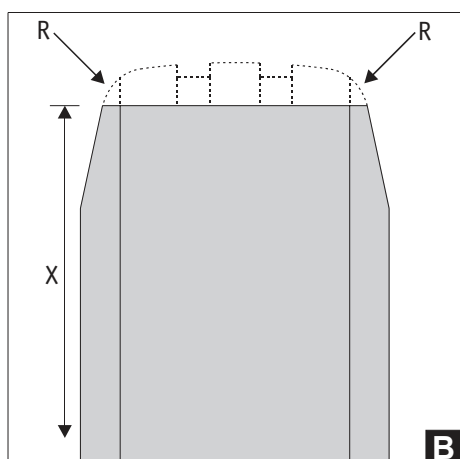

If you determine a worsening in the usual driving behaviour on your viamobil (i.e. erratic rolling away, wheelspinning or wheel-slipping), please contact your health care specialist for an inspection of the tyres.



Service and repairs to the viamobil are only to be carried out by an authorised specialist dealer or Alber. Please also contact your specialist dealer or the Alber Service Centre in the event that any faults occur.



11.3 Disposal

This device, its battery pack and accessories are long-lasting products. However, they may contain materials that prove to be hazardous for the environment if they are disposed of in places (e.g. landfills) that are not intended for this purpose according to the current applicable legislation in the respective country. The symbol of the “crossed-out refuse bin” (in accordance with WEEE Directive 2002/96/EC) is placed on this product to remind you of your obligation to recycle. Therefore, please act in an environmentally-conscious manner and bring this product to your regional recycling centre at the end of its service life. Please familiarise yourself with the applicable legislation in your country regarding disposal, because the WEEE Directive does not apply in all European States. For example, this product does not fall under the national implementation of WEEE in the Electrical and Electronic Equipment Act as means of transport. These components are also alternatively taken back by Alber or Alber dealers for proper, environmentally sound disposal.

11.4 Reuse

If you were provided with your viamobil by your health insurance and no longer require its use, please get in contact with your health insurance or health care specialist.

Your viamobil can then be simply and economically reused.

A safety-related inspection should be carried out on the viamobil before each reuse. The brackets, with which the viamobil is attached to the wheelchair, can be simply and easily removed from the wheelchair that no longer requires its services and attached to a new wheelchair by an authorised specialist dealer.

In addition to the apparent instructions on cleaning in chapter 11.2, the handle bar handles [7], operating button [12], and housing of the rechargeable battery pack [15] are to be disinfected prior to each reuse. Use a cleaning fluid suitable for disinfecting according to the instructions of the appropriate manufacturer.

11.5 Maintenance

Your viamobil requires a minimum of maintenance.

Nevertheless, we recommend checking regularly that all parts and accessories are securely fixed. In order to ensure that your viamobil is safe to drive and functioning correctly, it should undergo a technical inspection every 2 years at the latest. In particular, damage that has occurred during use that is not visible to the naked eye as well as wear and fatigue can thus be detected.

For this purpose, contact directly your authorized Alber dealer.

12. Warranty, Guarantee and Liability

12.1 Warranty for Defects

Alber guarantees that the viamobil is free from defects at the time of delivery. These warranty claims expire 24 months after delivery of the viamobil.

12.2 Service Life Guarantee

Alber provides a 24 month service life guarantee on the viamobil (exception: 12 months service life guarantee for the rechargeable battery pack)

The service life guarantee does not include the following:

- devices whose serial numbers have been changed, defaced or removed
- wear parts like, for example, brakes, tyres and control elements
- defects caused by natural wear and tear, improper treatment, especially defects due to non-observance of the operating instructions, accidents, negligent damage, effects of fire or water, force majeure and other causes, which are not within the sphere of influence of Alber.
- maintenance work resulting from daily utilisation (i.e. replacement of burnt-through fuses, replacement of tyres)
- appliance check without finding any defects

12.3 Liability

As the manufacturer of the viamobil, Ulrich Alber GmbH is not responsible for its safety if:

- the viamobil is handled improperly
- the viamobil is not serviced by an authorised specialist dealer of the Ulrich Alber GmbH every 2 years.
- the viamobil is started up contrary to the instructions in this instruction manual
- the viamobil is run with insufficient battery charge
- repairs or other work is carried out by unauthorised persons
- foreign parts are attached or connected to the viamobil
- parts of the viamobil are dismantled

Ihre Alber-Vertretung / Your Alber representative / Votre représentation Alber /
Vostra rappresentanza Alber / Su representación Alber / Din Alber representant /
Din Alber-agenturene / Uw distributeur Alber / Deres Alber-repräsentation



Ulrich Alber GmbH
Vor dem Weißen Stein 21
72461 Albstadt-Tailfingen
Telefon +49 (0)7432 2006-0
Telefax +49 (0)7432 2006-299
info@alber.de
www.alber.de

www.alber.de